



ব্রিলিয়ান্ট স্টারস স্কুল

(সি. বি. এস. ই. দ্বারা অনুমোদিত)

পূর্ব ধ্বজনগর, উদয়পুর, গোমতী, ত্রিপুরা, ভারত।
ষাণ্মাসিক মূল্যায়ন নমুনা পত্র বর্ষভাগ - ২০২৪-২৫
বিষয়- বাংলা শ্রেণী- ত্
সময়- ২ ঘণ্টা পূর্ণমান - ৬০

-
- এই প্রশ্নপত্রের উত্তরগুলি উত্তরপত্রের মধ্যেই লিখতে হবে।
-প্রশ্নপত্রটি পড়ার জন্য প্রথম দশ মিনিট ধার্য করা আছে।
-প্রশ্নপত্রের উপরে লিখিত নির্ধারিত সময়ের মধ্যেই উত্তরগুলি লিখতে হবে।
-এই প্রশ্নপত্রে ১৩ নম্বর পর্যন্ত প্রশ্ন আছে ও মোট ৫টি পৃষ্ঠা বিদ্যমান।
-

শিক্ষার্থীর নাম _____

১। শব্দার্থ লিখঃ

১X৫=৫

দিবস _____

দিঘি _____

মায়্যা _____

নিবির _____

রবি _____

২। একটি বাক্যে উত্তর দাওঃ (যে কোন ৫টি প্রশ্নের উত্তর লিখ)

১X৫= ৫

অ) কবি সারা বেলা ভয় কেন ?

আ) কি দেখে মেয়েরা কেদেছিল ?

ই) কানাই বলাই কি করে ?

ঈ) শকন্তলার দুই সখির নাম কি ছিল ?

উ) আমরা কেমন সুরে গান গাই ?

ঊ) সুধা কে ?

ঋ) কারা ঘাস হয়ে ফুটে উঠে ?

৩। সঠিক উত্তরটির নিচে দাগ দাও:

১X৬=৬

অ) মহর্ষি কথ দেবের আশ্রমের বটগাছটি ছিল _____

২ হাজার / ৩ হাজার / ১ হাজার বছরের পুরানো

আ) ঘাসের ছোট ফুল গুলি মাথা দোলায় _____

হাওয়াতে / শিশিরে/ ঝড়ে

ই) হিংসুটির আসল নাম _____

লক্ষ্মী/ স্বরসতী / কোনটি নয়

ঈ) মল পরে যাচ্ছিল _____

রাধা / সুধা / শশী

উ) নয়নমণি বলতে বুঝানো হয়েছে _____

মুসলমানকে / হিন্দুকে / মানুষকে

ঊ) দীঘিটি অবস্থিত পাড়ার _____

মাঝখাণে/ প্রান্তে / পাশে

৪। দু-একটি বাক্যে নিচের প্রশ্নগুলির উত্তর দাও:

২x৫=১০

ক) ঋষি কুমারদের কী কী কাজ ছিল?

খ) কবি সারাবেলা ভয় পান কেন ?

গ) 'একদিন সে ভাবতে বসল'।কে, কী ভাবতে বসলো

ঘ) হরি মোদি দোকানে কী কী বেঁচে ?

ঙ) কবি হিন্দু মুসলমান কে আর কিসের সঙ্গে তুলনা করেছেন ?

৫) নীচের শব্দ গুলির বিপরীত অর্থ লিখো:

১X৫=৫

শুরু _____

শীতল _____

বোকা _____

হিম _____

দুষ্টু _____

৬) এলোমেলো শব্দ গুলি সাজিয়ে লেখো:

১ X৫=৫

কয়াণভ _____

তাসবা _____

লনবতা _____

দিরানসা _____

সুমকু _____

ব্যাকরণ

৭) নীচের প্রশ্নগুলির উত্তর দাও:

১X৬=৬

ক) ভাষা কাকে বলে ?

খ) তোমার মাতৃভাষা কি ?

গ) ধ্বনি কাকে বলে ?

৮) লিঙ্গ পরিবর্তন কর:

১X৬=৬

মানব _____

পাঠিকা _____

কপত _____

দাস _____

বালক _____

ছাত্র _____

৯) নীচের শব্দগুলির অর্থের পার্থক্য:

১X৬=৬

বিশ _____

শম _____

শর _____

সর _____

বিষ _____

সম _____

১০। বিদ্যালয়ে অনুপস্থিত থাকার কারণে প্রধান শিক্ষকের নিকট আবেদন পত্র।

৬



Brilliant Stars School

(Affiliated to CBSE)

East Dhajanagar, Udaipur, Gomati, Tripura

Term – 1
Subject – Computer
Class – III

Session - 2024-25
Max. Points –30
Time – 1hr

General Instructions –

- Answer to this question paper must be written in the answer script provided separately.
 - First 10 minutes has been allotted for reading the question paper.
 - The time mentioned above is the time allotted for writing answers.
 - This paper has 22 questions and 2 printed pages.
-

Name of the student: _____

A. Write true/False:

1x3=3

1. Pivot animator is an animation software.
2. The task bar is a vertical bar.
3. A printer is a software device.

B. Fill in the blanks:

1x3=3

1. Application software are _____ programs.
2. The speaker icon appears in the _____.
3. To close Pivot Animator, we need to click the _____ option.

C. Arrange the steps to insert a function in the correct order:

1x6=6

1. Select the desired screen saver.
2. Click on the down arrow to expand the screen saver list.
3. At the bottom of the window, click on the screen saver option.
4. Click on the personalize option.
5. On the desktop, right- click on an empty space.
6. Switch on the computer.

D. Finding out errors:

1x2=2

1. To delete a figure in pivot animator, you must click on the orange dot on the figure.
2. You cannot move an object from one location to another in MS Paint.

E. One word answer:

1x4=4

1. The parts of a computer that can be touched. _____.
2. The system software that runs the computer. _____.
3. Harmful software that slows down the computer and corrupts it. _____.
4. When the computer remains idle for some time, an image pops up on the screen. _____.

F. Short answer type questions:

3x4=12

1. What is the need of Pivot Animator?
2. What is the picture given below? Write the name of two icons showing here.

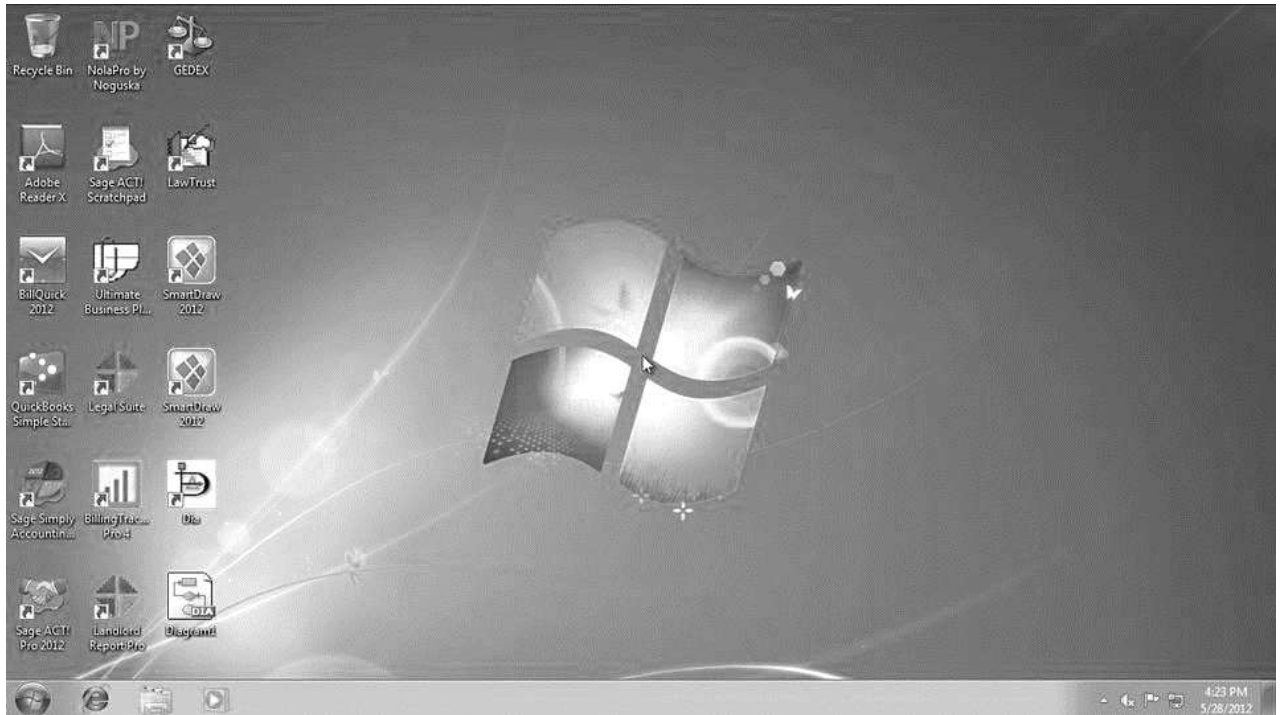

3. Draw a stick figure of Pivot animator.
4. Match the following:

Icons	Name
Ctrl+X	To play the animation
	Storage device
Play button	Cut
Hard disk	My Computer



Brilliant Stars School

(Affiliated to CBSE)

East Dhajanagar, Udaipur, Gomati, Tripura

Term – 1

Session - 2024-25

Subject – Environmental Science

Max.Points – 60

Class – III

Time – 1 hour 20 minutes

Sample Question Paper

Instructions –

- Answer to this question paper must be written on the same question paper itself.
 - First 10 minutes has been allotted for reading the question paper.
 - The time mentioned above is the time allotted for writing answers.
 - This paper has 18 questions and 8 printed pages.
-

Name _____ Date _____

Part 1: Objective Type Questions

(1x20=20)

1. Choose the correct options.

A. The stem that stores food for the plant.

- i. carrot
- ii. cabbage
- iii. ginger

B. What do squirrels run away on hearing a sound to protect themselves?

- i. Loud sound
- ii. Meeting other
- iii. Danger

C. Tick the internal organs

- i. head
- ii. lung
- iii. liver

D. Tick the things that leaves need to make food.

- i. salt
- ii air
- iii. Water

E. Seeds eaten as nut.

- i. chick pea
- ii. almond
- iii. Cumin seed

F. The body of an insects is divided into _____

- i. seven parts

- ii. three parts
- iii. two parts

- G. Blood vessel is a part of
- i. Respiratory System
 - ii. Digestive System
 - iii. Circulatory System

- H. Breathing out air from the nose is called
- i. Exhalation
 - ii. Breathing System
 - iii. Inhalation

- I. The activities which may cause breathing problem.
- i. Inhaling smoke for many days
 - ii. Talking to an asthma patient
 - iii. Drinking dirty water

2. Choose True or False.

- i. We should eat healthy food to keep our organs in good health.
- ii. Plants do not need food.
- iii. Liver is a part of nervous system. _____
- iv. Seeds make food for the plant. _____
- v. Grasshopper have tube-like mouths. _____
- vi. Houseflies have mouth parts to cut, and bite food. _____
- vii. Carbondioxide is used by our bodies to get energy from food. _____

3. Write 1 use of each object.

kite- _____

bed- _____

wood- _____

4. Match the column

- | | | | |
|--------------------|---|---|--------------|
| a. Blades of a fan | - | - | i. soil |
| b. Tyres | - | - | ii. rubber |
| c. Bucket | - | - | iii. plastic |
| d. Flowerpot | - | - | iv. metal |

Part 2: Short Answer Type Question

2x5=10

5. Look at the pictures and name the organ system.

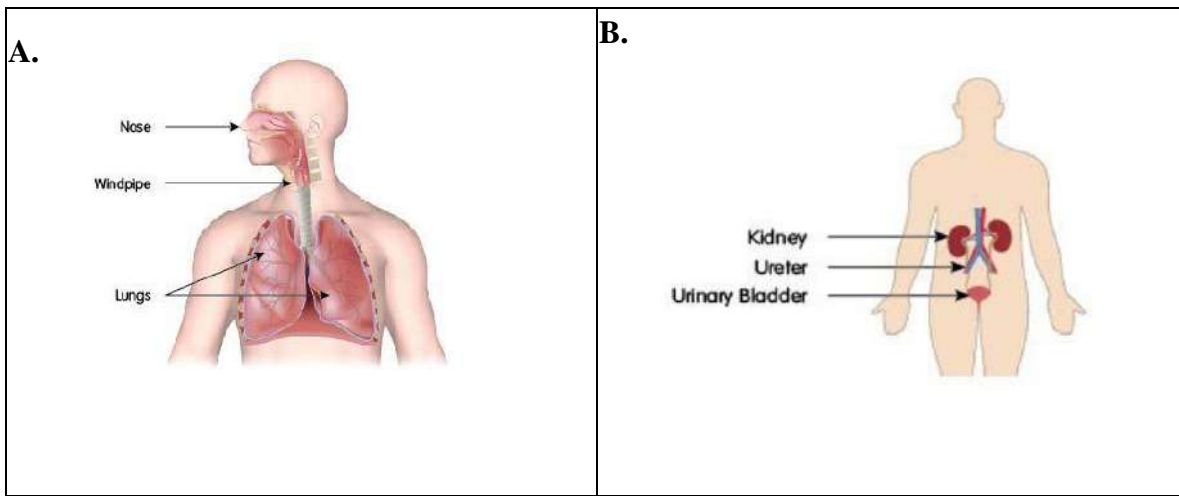

6. Ananya has severe pain in her stomach. She is not able to eat anything. Which organ system

Of her body is not working properly? Why -

7. Look at the pictures of the nests of birds. Fill in the blanks with the materials the birds use to make their nests.



8. Match the type of beak with its function.

- a. Small and pointed
- b. Long and strong beak
- c. Curved and strong
- d. Thin, straw-like beak

- i. Pick up grains
- ii. Catch fish
- iii. Suck nectar
- iv. Break nuts

9. Label the organs in the picture.

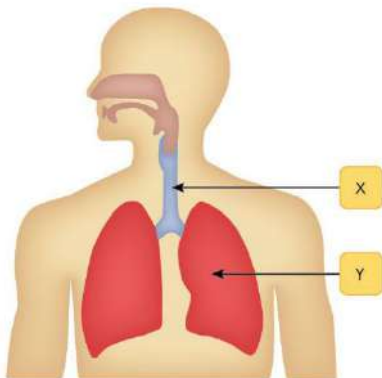

X _____

Y _____

Part 3. Short Answer Type Questions

3x6=18

10. Look at the roots of the beetroot plant and the tomato plant and answer the following questions:

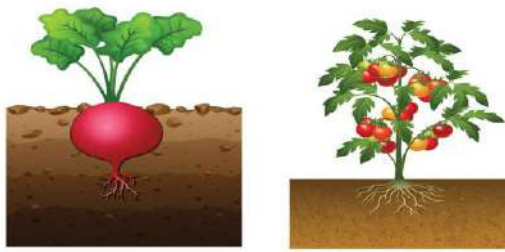

A. Which of these roots do we eat? _____ (1)

B. Why do the roots of the beetroot plant look different from the roots of the tomato plant? (2)

11. Choose words to label the body parts of a beetle.

Head abdomen Thorax antennae Legs

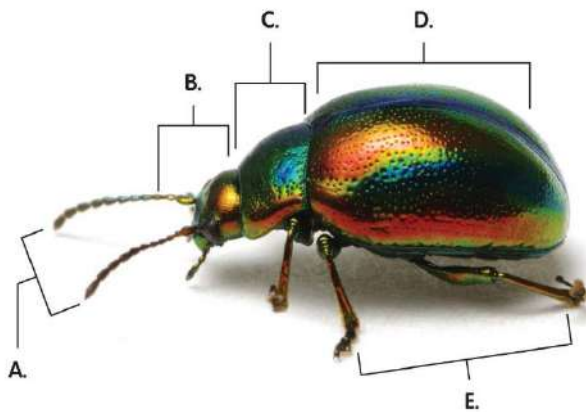

A: _____

B: _____

C: _____

D: _____

E: _____

12. Raman has been passing hard stools for 2–3 days. He has also been complaining of a stomach-ache.

A. Which organ system in his body is not working properly?

B. Give a reason for your answer.

13. Look at the pictures of the life cycle of two insects. Answer the questions.

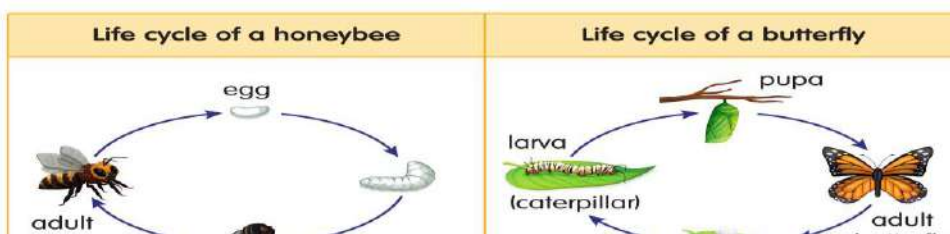

A. Write 1 similarity between the life cycles of the two insects. (1.5)

B. Write 1 difference between the pupa stages in the life cycles of the two insects. (1.5)

14. Write 1 use of each seed: groundnut and mustard. (3)

15. Write 2 things that we should avoid doing to keep our respiratory system healthy.

Part 4: Long Answer Type Question

4x3=12

16. Look at the picture and answer the questions.





Blue Whale

A Which organ does the blue whale use to breathe?

B. Why do we see the whale coming up to the surface of water often?

17. Look at the pictures and answer the questions.

	
Picture 1	Picture 2

A. Which picture is a fruit?

B. Give a reason for your choice.

18. Sam waters the leaves of his plant while Tina waters the soil in which her plant grows.. Which method of watering plant is better? Why?



Brilliant Stars School

(Affiliated to CBSE)

East Dhajanagar, Udaipur, Gomati, Tripura

Term- 1 (Sample Question)
Subject-Mathematics
Class-III

Session-2024-25
Max.Points -60
Time- 2hrs

Instructions-

- Answer to this question paper must be written on the same question paper itself.
- First 10 minutes has been allotted for reading the question paper.
- The time mentioned above is the time allotted for writing answers.
- This paper has 13 printed pages.

Student's Name: _____

Date: _____

A. Very short answer questions

20 marks

1. Choose the correct option to complete the sentences: 1

160

300

A. $20 \times 8 =$ _____

B. $6 \times 50 =$ _____

2. Choose the picture that shows 7-6. 1



3. Choose the correct option to complete the sentences 1

21

3

7

Fill in the blanks by writing the multiplication sentence in another way.

$3 \times 7 = 21 \Rightarrow$ _____ \times _____ $=$ _____

4. Match the repeated addition sentences with their multiplication sentences. 1

a. $3+3+3+3$

•

• $2 \times 5 = 10$

b. $4+4+4$

•

• $5 \times 2 = 10$

c. $5+5$

•

• $4 \times 3 = 12$

d. $2+2+2+2+2$

•

• $3 \times 4 = 12$

5. Choose if True or False. 1

A. On multiplying 23 and 11, we get 2 in the ones place of the product.

B. On multiplying 41 and 12, we get 9 in the tens place of the product.

6. Match the subtraction fact with the correct answer.

1

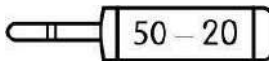
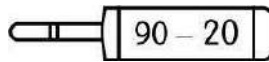
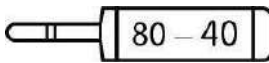
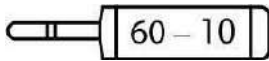

7. Choose the correct option to complete the sentences

1

541 tens ones 8

Fill in the blanks.

A. 289 has 2 hundreds, _____ tens, and 9 _____.

B. 5 hundreds, 4 _____, and 1 one make the number _____.

8. Look at the numbers given below and fill in the blanks with <, >, or =.

1

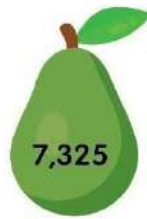

A.  _____



B.  _____



C.  _____



D.  _____



9. Fill in the blanks:

1

A. $556+30=$ _____

B. $465+200=$ _____

10. The roll numbers of 4 students are 7,308; 7,320; 7,312; and 7,305. Arrange the roll numbers in ascending order.

1

11. Guess the 4-digit number using these clues

1

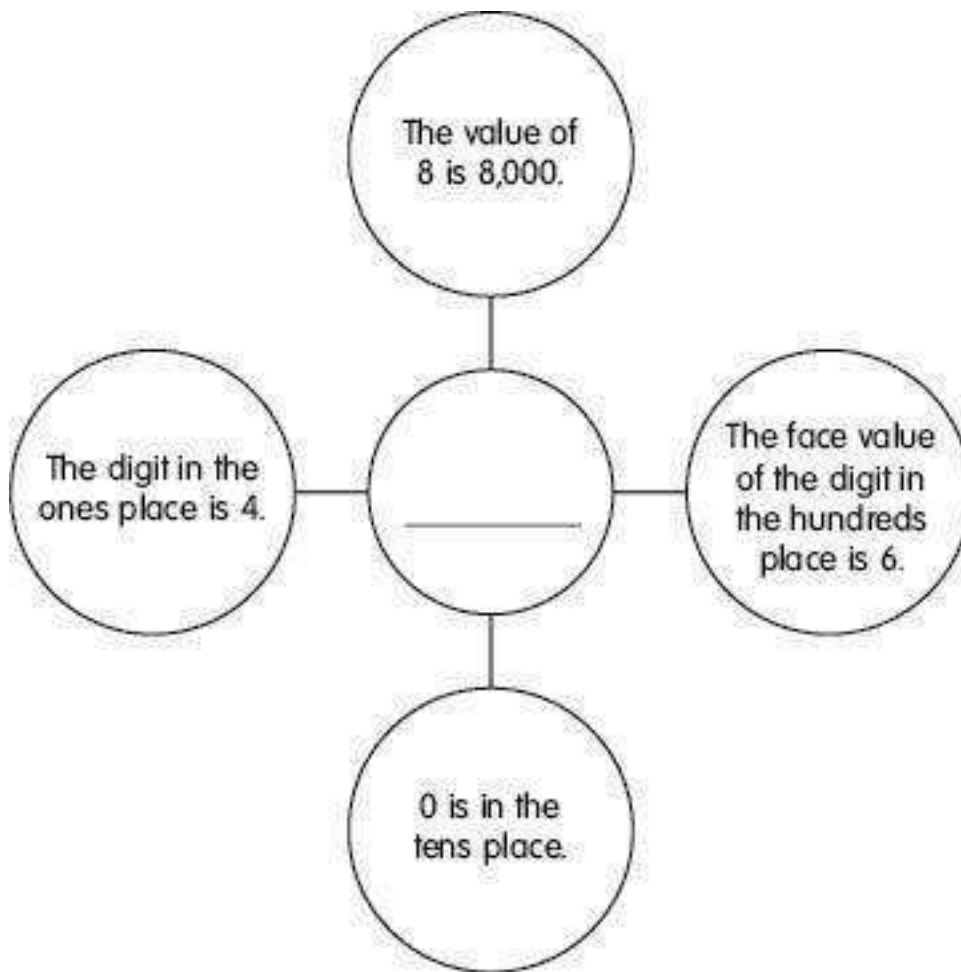

12. Add the numbers mentally and match them with the correct numbers.

1

$40+20$ $60+20$ $10+20$ $70+20$

90

60

80

30

40

13. Write the number on the books to arrange them in descending order.

1

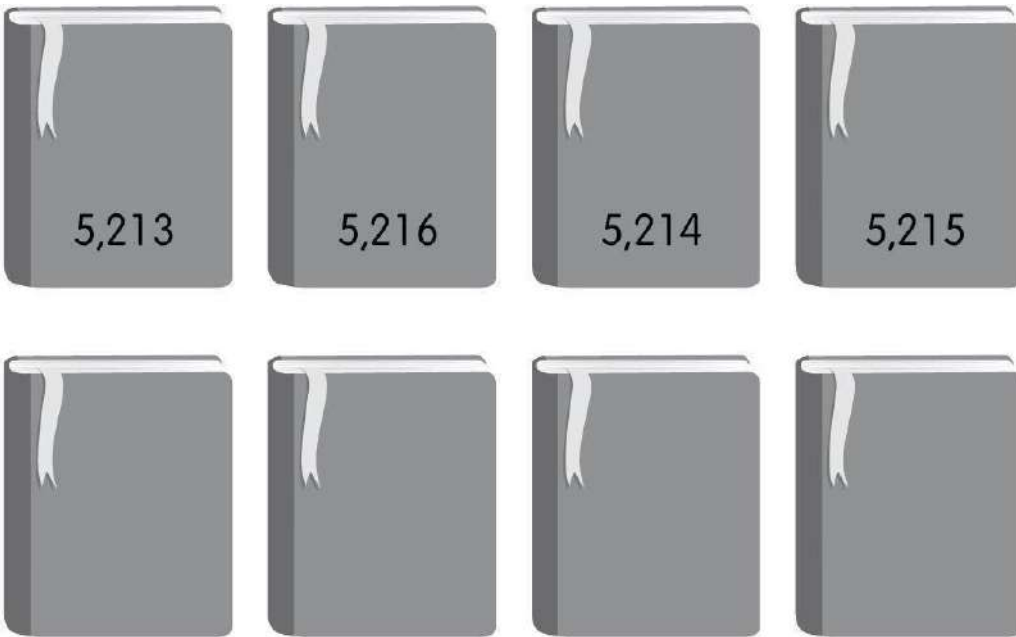

14. The art teacher wants to give 3 different coloured sheets of paper to each student in the class. If there are 7 students in the class, how many sheets of paper will the teacher need for the class?

1

15. Fill in the missing parts

1

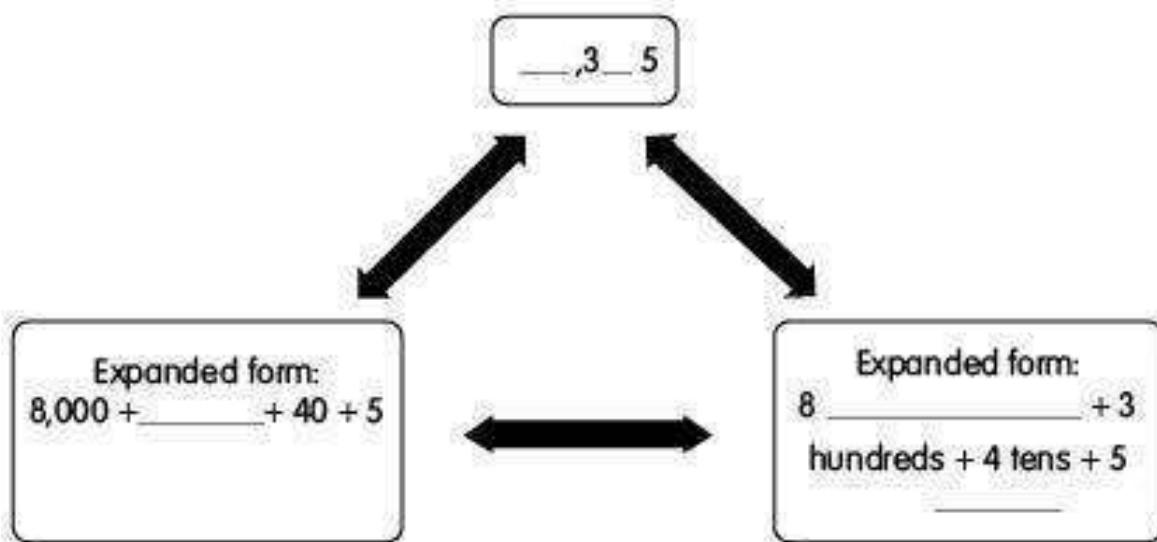

16. Choose if True or False.

1

A. The smallest number among 4,000; 3,500; and 2,500 is 4,000.

B. The greatest number among 1,600; 1,800; and 8,400 is 8,400.

17. Write the value of the beads on the abacus. Draw beads for the given values.

1

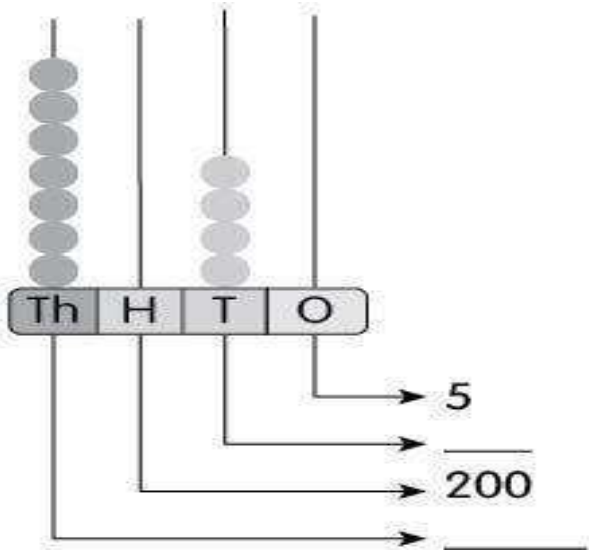

18. Choose the multiplication that does NOT give the same answer as the other two.

1

A. 12×8

B. 2×48

C. 19×5

19. Subtract and choose the correct answer.

1

A. $698 - 50$

i. 198

ii. 648

iii. 693

iv. 640

B. 748–300

i. 448

ii. 718

iii. 715

iv. 400

20. Fill in the blanks

1

A. On skip counting forward from 9,816 by 10, we get the number _____.

B. On skip counting backward from 3,277 by _____, we get the number 3,177.

B. Short answer questions

10 marks

21. Choose the correct option to complete the sentences

2

46

66

32

Tom used 32 oranges and 34 sweet limes to make juice. He used _____ fruits in total to make juice.

22. Match the following.

2

a. The number after 876 is i. 146

b. The number before 479 is ii. 655

c. The number between 145 and 147 is iii. 877

d. The number between 654 and 656 is iv. 478

23. Start from the number 6,056. Write the correct number.

2

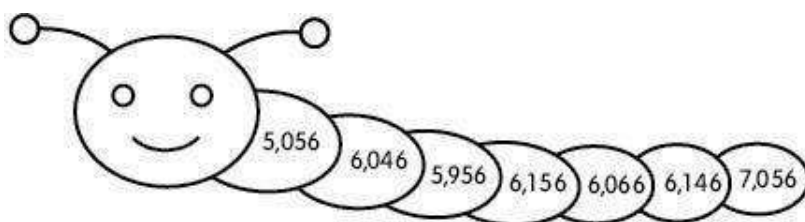

A. Write the number that you will get on skip counting forward by 10.

B. Write the number that you will get on skip counting backwards by 100.

24. Draw a picture to show that 24 divided by 4 is 6. Write the division sentence.

2

25. Colour all those numbers that appear in the multiplication table of 8 yellow.

2

14	24	36	42
48	49	54	51
50	65	72	78
62	64	70	80

C. Long answer questions

30 marks

26. Sue and Ray went out to play.

3

A. They started writing some numbers on the ground to play a hopping game.

a. From the number 4,567, Sue hops to the 10th number. Write all the missing numbers.

1	2	3	4	5	6	7	8	9	10
4,567	4,568								

b. From the number 8,655, Ray hops to the 4th number. Write all the numbers.

11	10	9	8	7	6	5	4
8,655	8,654						

B. Then, they went home. They climbed up the stairs to reach their house.

Write the numbers to find the number of the last step.

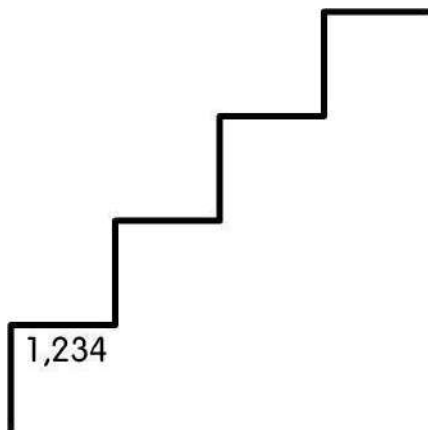

27. Divide by repeated subtraction and write the division sentence

3

A. 45 by 9

B. 48 by 6

28. Multiply using the column method.

3

A. 28×42

B. 43×18

29. Write a word problem on multiplication by using 54 and 32.

3

30. Tina distributed 12 toys equally among 2 friends. Tom distributed 14 toys equally among 7 friends. 3

A. How many toys did each of Tina's friends get?

B. How many toys did each of Tom's friends get?

C. Whose friends got more toys?

31. Kim shared 24 biscuits with his friends by giving 4 to each. How many friends did Kim share the biscuits with? 3

32. Solve the riddles to find the digits, and form the greatest and the smallest numbers with them.

4

Greatest 4-digit number without repeating the digits	Smallest 4-digit number without repeating the digits
--	--

33. Yen has ₹589. Answer the questions. Show your work

4

A. If he wants to buy a comic worth ₹250, how much money will be left with him?

B. If he wants to buy a video game worth ₹475, how much money will he have left?

34. Milo has made some groups of pencils. Count the number of groups of pencils, and write the multiplication sentence.

4

